

8 7 6 5 4 3 2 1

REVISIONS				
ZONE	REV.	DESCRIPTION	DATE	APPROVED
	A	NEW RELEASE	3/10/2023	BJJ

**DISCLAIMER:**  
 THE INFORMATION CONTAINED IN THIS DRAWING IS FOR CONCEPTUAL REFERENCE ONLY AND IS NOT INTENDED TO SERVE AS COMPLETE INSTRUCTIONS FOR SAFE CONSTRUCTION AND OPERATION. BY REFERENCING THIS DRAWING, IT IS UNDERSTOOD THAT MCGUIRE MECHANISM LLC IS TO BE HELD HARMLESS AND RELEASED OF ALL LIABILITY FROM ANY INJURIES AND PROPERTY DAMAGES RESULTING FROM ACTIVITIES ASSOCIATED WITH THIS DRAWING'S INFORMATION.

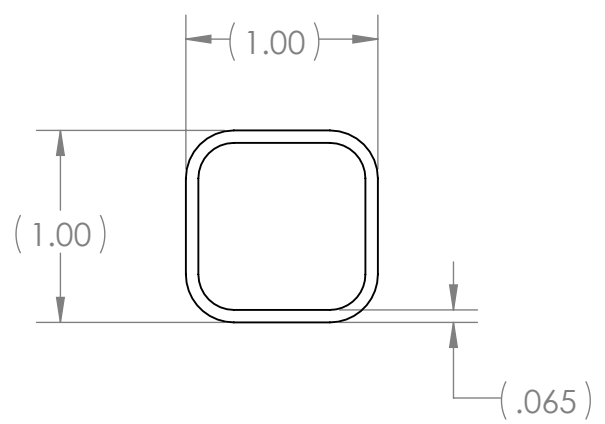
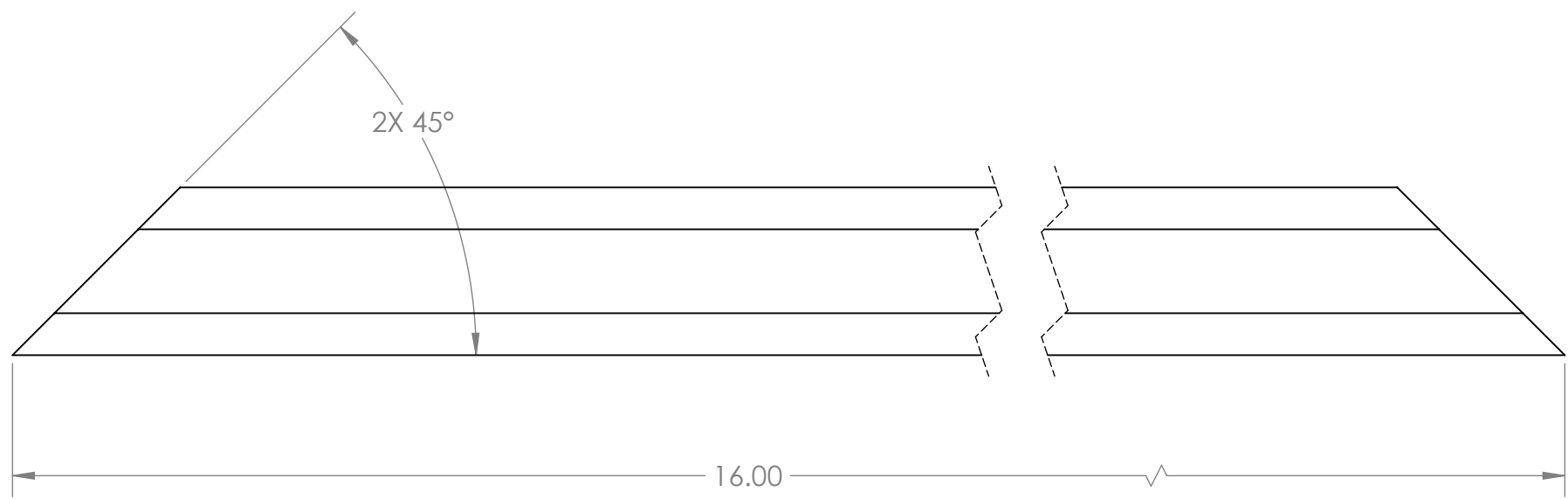

**RWC01-402(SHEET 1 OF 1)  
 FRAME GUSSET (LARGE)**

**PROPRIETARY AND CONFIDENTIAL**  
 THE INFORMATION CONTAINED IN THIS DRAWING IS THE SOLE PROPERTY OF MCGUIRE MECHANISM. ANY REPRODUCTION IN PART OR AS A WHOLE WITHOUT THE WRITTEN PERMISSION OF MCGUIRE MECHANISM IS PROHIBITED.

UNLESS OTHERWISE SPECIFIED:		DATE	NAME
DIMENSIONS ARE IN INCHES		3/10/2023	BJJ
TOLERANCES:			
FRACTIONAL ± 1/8"			
ANGULAR: MACH ± 0.1°			
BEND ± 2°			
TWO PLACE DECIMAL ± .030			
THREE PLACE DECIMAL ± .005			
FOUR PLACE DECIMAL ± .0005			
MATERIAL	Plain Carbon Steel		
FINISH			

DRAWN	3/10/2023	BJJ
CHECKED		
ENG APPR.		
MFG APPR.		
Q.A.		
COMMENTS:		

**McGuire Mechanism**

SIZE	DWG. NO.	REV
B	RWC01-402	A
SCALE: 1:1	WEIGHT:	SHEET 1 OF 1

8 7 6 5 4 3 2 1