

FINISHED WELD INSTRUCTIONS SHEET 2

REVISIONS				
ZONE	REV.	DESCRIPTION	DATE	APPROVED
	A	NEW RELEASE	3/3/2023	BJJ

NO.	QTY.	PART NUMBER	DESCRIPTION
1	2	RAIN BARREL	55 GAL CLOSED TOP HDPE DRUM
2	1	RWC01-300	PERIMETER FRAME
3	10	RWC01-401	FRAME FLOOR
4	4	RWC01-403	FRAME GUSSET (SMALL)
5	4	RWC01-402	FRAME GUSSET (LARGE)
6	4	RWC01-404	FRAME FOOT

DISCLAIMER:
 THE INFORMATION CONTAINED IN THIS DRAWING IS FOR CONCEPTUAL REFERENCE ONLY AND IS NOT INTENDED TO SERVE AS COMPLETE INSTRUCTIONS FOR SAFE CONSTRUCTION AND OPERATION. BY REFERENCING THIS DRAWING, IT IS UNDERSTOOD THAT MCGUIRE MECHANISM LLC IS TO BE HELD HARMLESS AND RELEASED OF ALL LIABILITY FROM ANY INJURIES AND PROPERTY DAMAGES RESULTING FROM ACTIVITIES ASSOCIATED WITH THIS DRAWING'S INFORMATION.

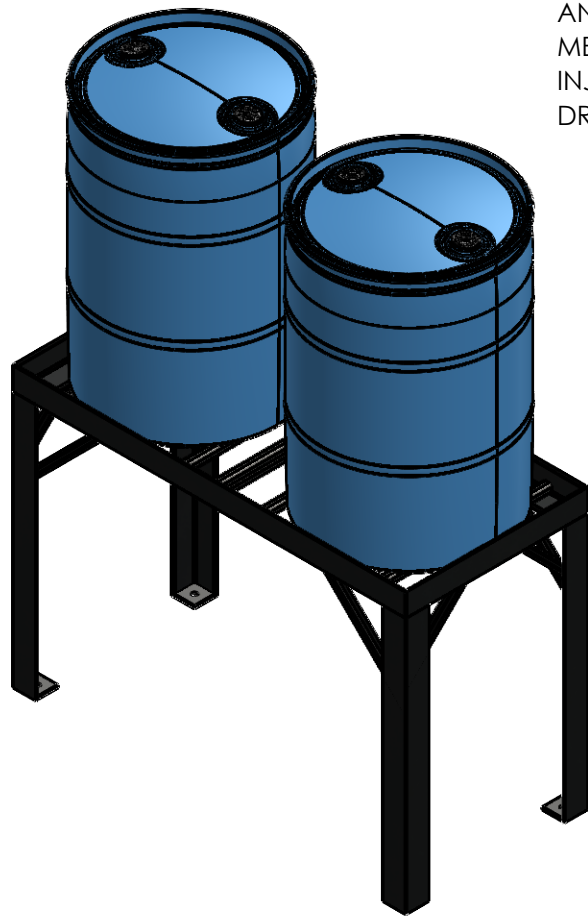
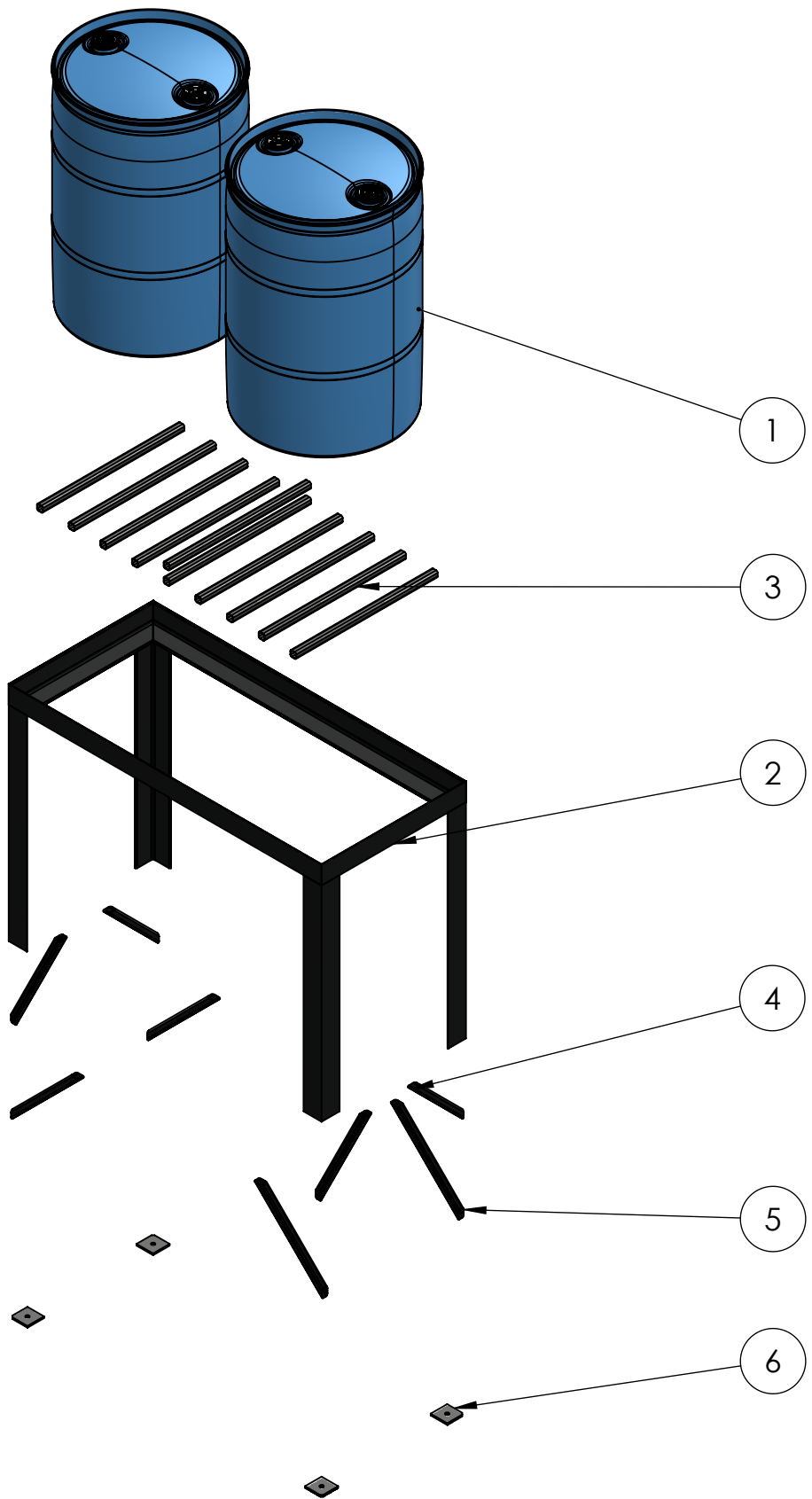

**RWC01-400(SHEET 1 OF 2)
 2-DRUM RAISED RAINWATER COLLECTION SYSTEM**

PROPRIETARY AND CONFIDENTIAL
 THE INFORMATION CONTAINED IN THIS DRAWING IS THE SOLE PROPERTY OF MCGUIRE MECHANISM. ANY REPRODUCTION IN PART OR AS A WHOLE WITHOUT THE WRITTEN PERMISSION OF MCGUIRE MECHANISM IS PROHIBITED.

UNLESS OTHERWISE SPECIFIED:		DATE	NAME						
DIMENSIONS ARE IN INCHES		DRAWN	3/3/2023						
TOLERANCES:		CHECKED	BJJ						
FRACTIONAL ± 1/8"		ENG APPR.							
ANGULAR: MACH ± 0.1°		MFG APPR.							
BEND ± 2°		Q.A.							
TWO PLACE DECIMAL ± .030		COMMENTS:							
THREE PLACE DECIMAL ± .005									
FOUR PLACE DECIMAL ± .0005									
MATERIAL									
FINISH		<table border="1"> <tr> <td>SIZE</td> <td>DWG. NO.</td> <td>REV</td> </tr> <tr> <td>B</td> <td>RWC01-400</td> <td>A</td> </tr> </table>		SIZE	DWG. NO.	REV	B	RWC01-400	A
SIZE	DWG. NO.	REV							
B	RWC01-400	A							
		SCALE: 1:16 WEIGHT: 116LBS SHEET 1 OF 2							

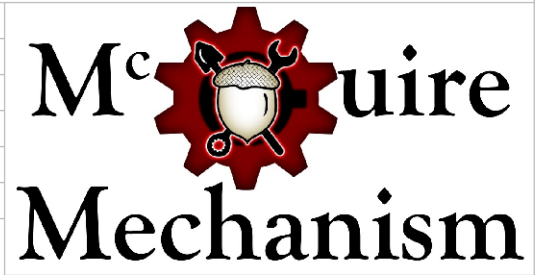

8 7 6 5 4 3 2 1

REVISIONS				
ZONE	REV.	DESCRIPTION	DATE	APPROVED
-	-	See Sheet1	-	-

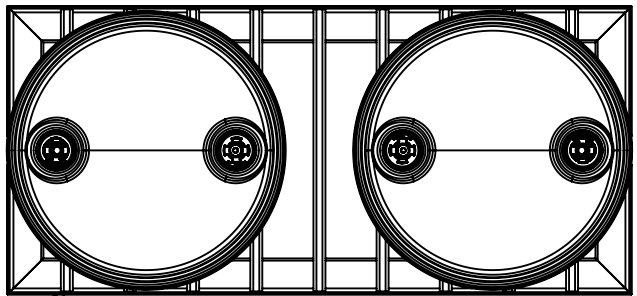

1/16
WELD TUBING EQUAL SPACED ON TOP OF ANGLE IRON
4.26 TYP

DISCLAIMER:
THE INFORMATION CONTAINED IN THIS DRAWING IS FOR CONCEPTUAL REFERENCE ONLY AND IS NOT INTENDED TO SERVE AS COMPLETE INSTRUCTIONS FOR SAFE CONSTRUCTION AND OPERATION. BY REFERENCING THIS DRAWING, IT IS UNDERSTOOD THAT MCGUIRE MECHANISM LLC IS TO BE HELD HARMLESS AND RELEASED OF ALL LIABILITY FROM ANY INJURIES AND PROPERTY DAMAGES RESULTING FROM ACTIVITIES ASSOCIATED WITH THIS DRAWING'S INFORMATION.

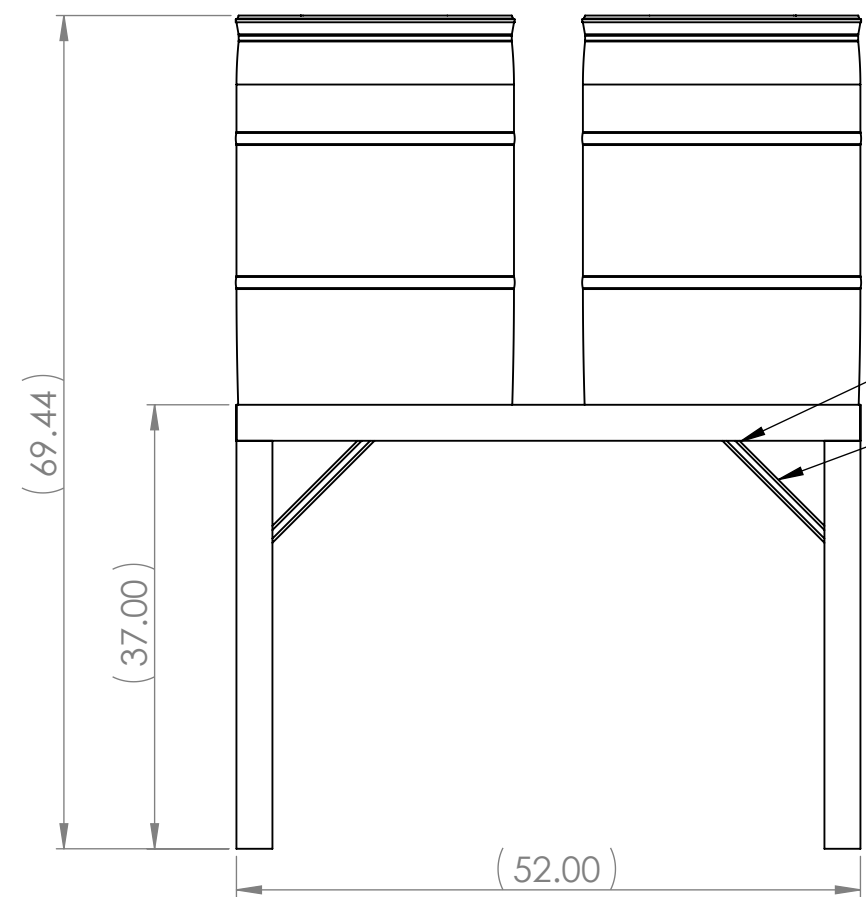

(69.44)
(37.00)
(52.00)
3/32
WELD GUSSETS FLUSH WITH TOP AND SIDE OF ANGLE IRON

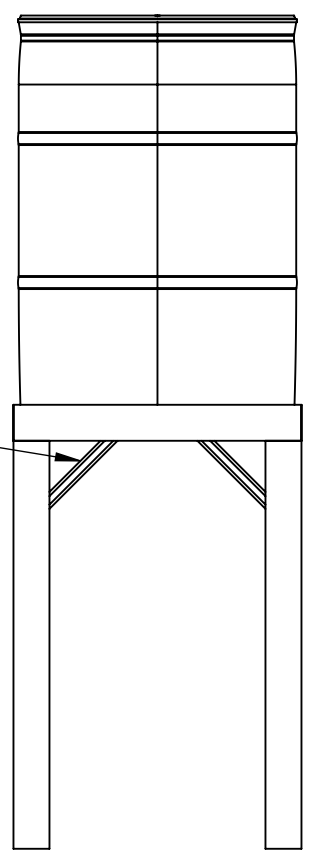

**RWC01-400(SHEET 2 OF 2)
2-DRUM RAISED RAINWATER COLLECTION SYSTEM**

PROPRIETARY AND CONFIDENTIAL
THE INFORMATION CONTAINED IN THIS DRAWING IS THE SOLE PROPERTY OF MCGUIRE MECHANISM. ANY REPRODUCTION IN PART OR AS A WHOLE WITHOUT THE WRITTEN PERMISSION OF MCGUIRE MECHANISM IS PROHIBITED.

UNLESS OTHERWISE SPECIFIED:	DATE	NAME
DIMENSIONS ARE IN INCHES	DRAWN 3/3/2023	BJJ
TOLERANCES:	CHECKED	
FRACTIONAL ± 1/8"	ENG APPR.	
ANGULAR: MACH ± 0.1°	MFG APPR.	
BEND ± 2°	Q.A.	
TWO PLACE DECIMAL ± .030	COMMENTS:	
THREE PLACE DECIMAL ± .005		
FOUR PLACE DECIMAL ± .0005		
MATERIAL		
FINISH		

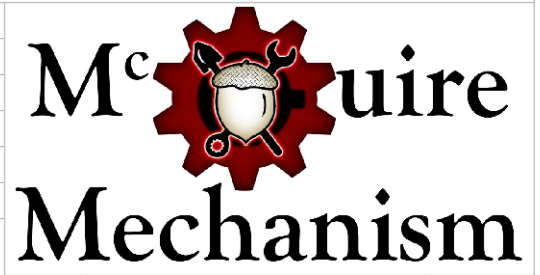

SIZE B	DWG. NO. RWC01-400	REV A
SCALE: 1:16	WEIGHT:	SHEET 2 OF 2

8 7 6 5 4 3 2 1