

8 7 6 5 4 3 2 1

NOTE:
 • FRAME PERIMETER SHOWN ONLY. GUESSETS AND CROSS MEMBERS SHOWN ON SHEET 2 OF RWC01-400.

REVISIONS				
ZONE	REV.	DESCRIPTION	DATE	APPROVED
	A	NEW RELEASE	3/10/2023	BJJ

ITEM NO.	QTY.	DESCRIPTION	LENGTH
1	2	L3x3x0.1875	24
2	2	L3x3x0.1875	52
3	4	L3x3x0.1875	34

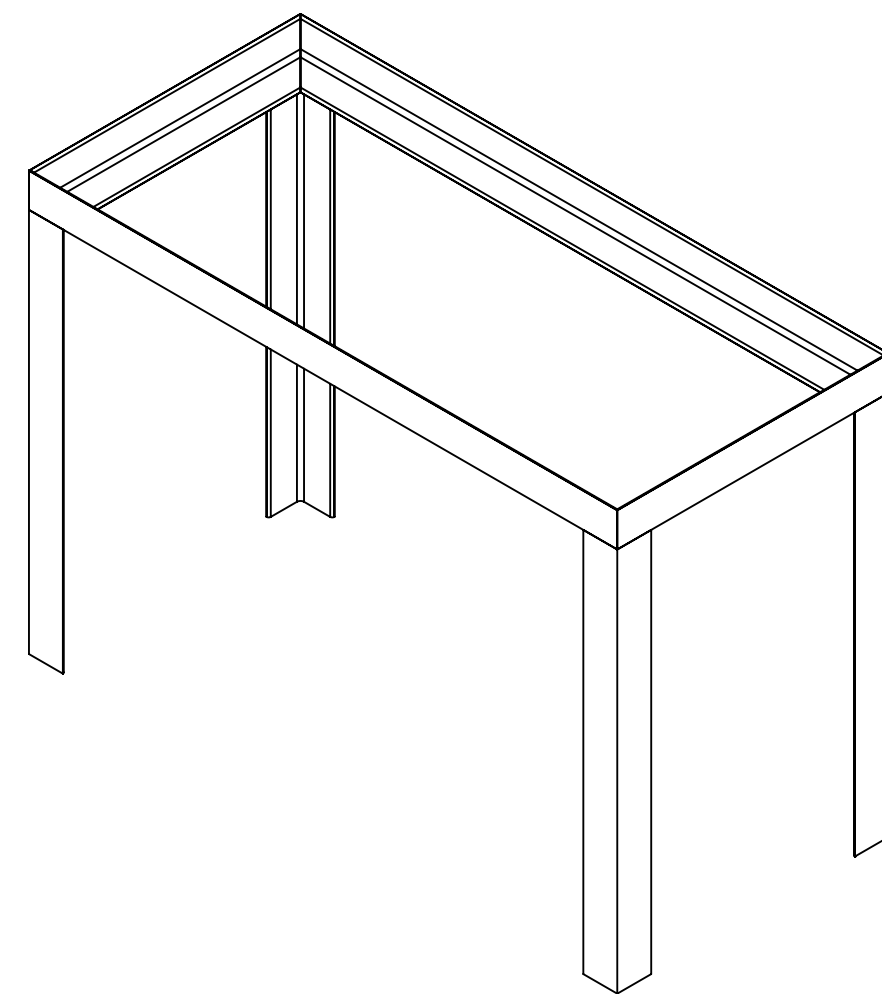
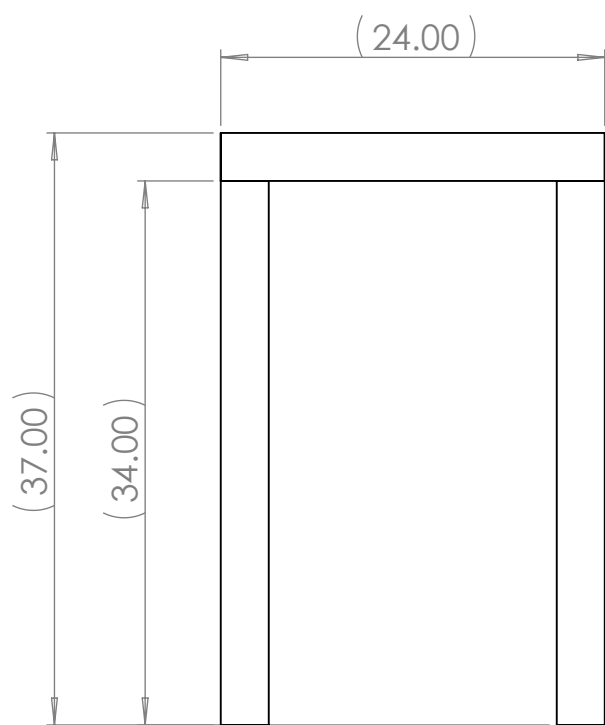
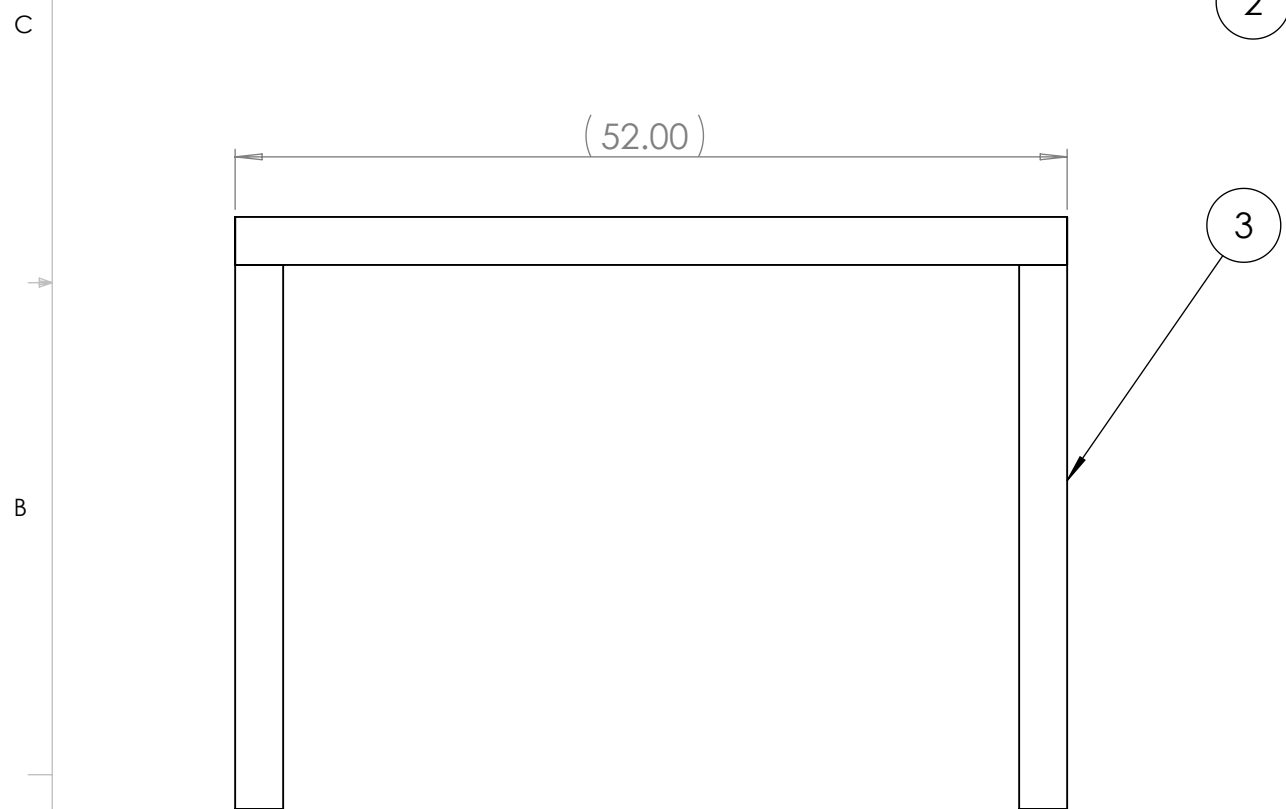
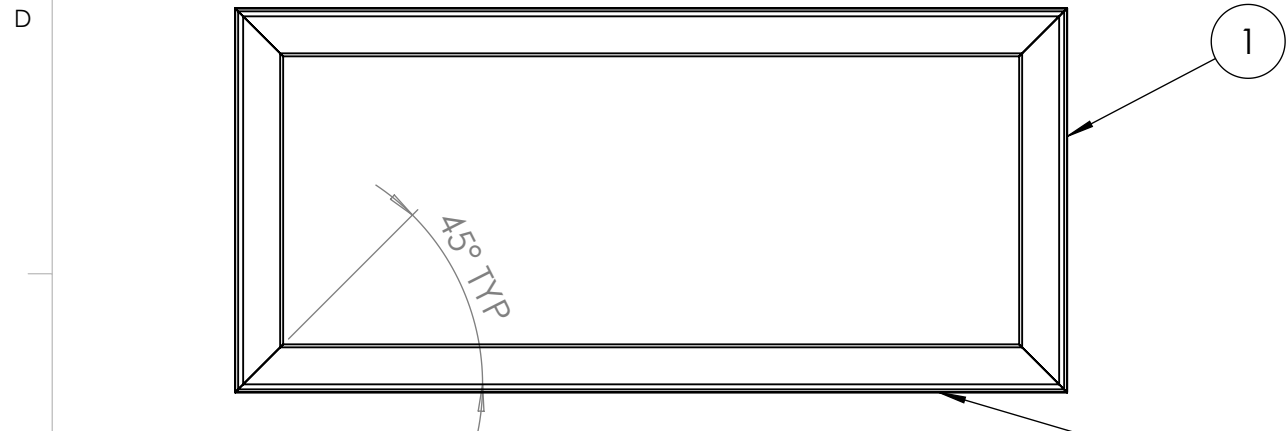

A

**RWC01-300(SHEET 1 OF 1)
 PERIMETER FRAME**

DISCLAIMER:
 THE INFORMATION CONTAINED IN THIS DRAWING IS FOR CONCEPTUAL REFERENCE ONLY AND IS NOT INTENDED TO SERVE AS COMPLETE INSTRUCTIONS FOR SAFE CONSTRUCTION AND OPERATION. BY REFERENCING THIS DRAWING, IT IS UNDERSTOOD THAT MCGUIRE MECHANISM LLC IS TO BE HELD HARMLESS AND RELEASED OF ALL LIABILITY FROM ANY INJURIES AND PROPERTY DAMAGES RESULTING FROM ACTIVITIES ASSOCIATED WITH THIS DRAWING'S INFORMATION.

PROPRIETARY AND CONFIDENTIAL
 THE INFORMATION CONTAINED IN THIS DRAWING IS THE SOLE PROPERTY OF MCGUIRE MECHANISM. ANY REPRODUCTION IN PART OR AS A WHOLE WITHOUT THE WRITTEN PERMISSION OF MCGUIRE MECHANISM IS PROHIBITED.

UNLESS OTHERWISE SPECIFIED:		DATE	NAME
DIMENSIONS ARE IN INCHES		3/10/2023	BJJ
TOLERANCES:			
FRACTIONAL ± 1/8"			
ANGULAR: MACH ± 0.1°			
BEND ± 2°			
TWO PLACE DECIMAL ± .030			
THREE PLACE DECIMAL ± .005			
FOUR PLACE DECIMAL ± .0005			
MATERIAL	Plain Carbon Steel		
FINISH			

DRAWN	3/10/2023	BJJ
CHECKED		
ENG APPR.		
MFG APPR.		
Q.A.		
COMMENTS:		

McGuire Mechanism

SIZE B	DWG. NO. RWC01-300	REV A
SCALE: 1:12	WEIGHT:	SHEET 1 OF 1

8 7 6 5 4 3 2 1