

REVISIONS				
ZONE	REV.	DESCRIPTION	DATE	SIGNED
	A	NEWRELEASE	11/22/2022	BJJ

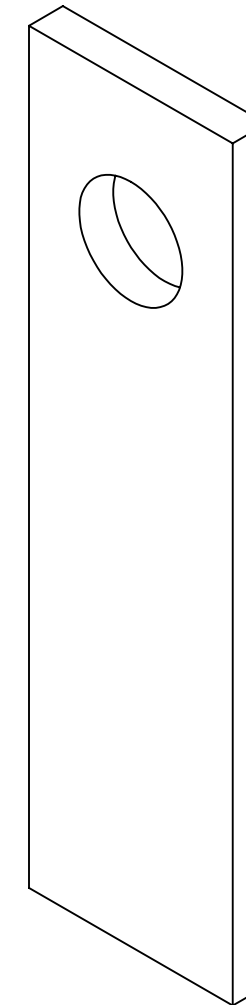
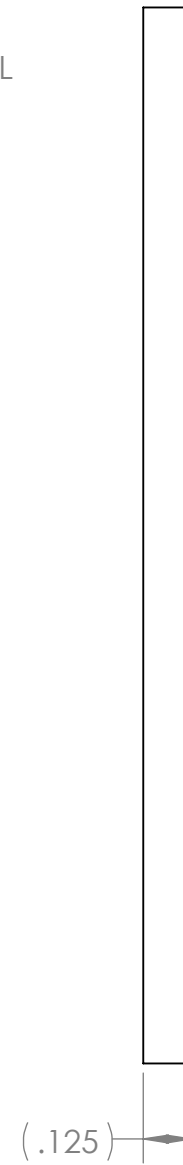
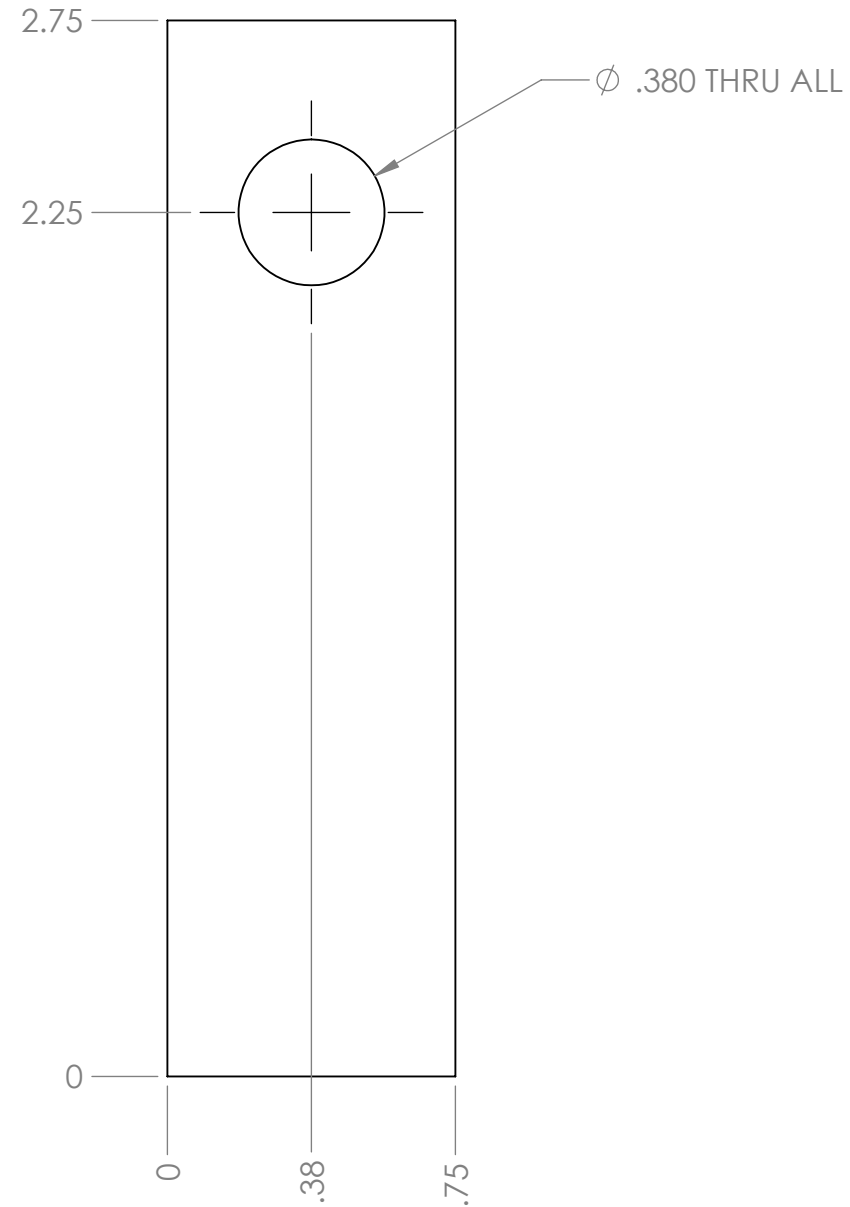

**HNC-03(SHEET 1 OF 1)  
FRONT FOOT**

UNLESS OTHERWISE SPECIFIED:

DIMENSIONS ARE IN INCHES  
 TOLERANCES:  
 FRACTIONAL ± 1/8"  
 ANGULAR: MACH ± 0.1°  
 BEND ± 2°  
 TWO PLACE DECIMAL ± .030  
 THREE PLACE DECIMAL ± .005  
 FOUR PLACE DECIMAL ± .0005

MATERIAL PLAIN CARBON STEEL

FINISH

**PROPRIETARY AND CONFIDENTIAL**  
 THE INFORMATION CONTAINED IN THIS DRAWING IS THE SOLE PROPERTY OF MCGUIRE MECHANISM. ANY REPRODUCTION IN PART OR AS A WHOLE WITHOUT THE WRITTEN PERMISSION OF MCGUIRE MECHANISM IS PROHIBITED.

	DATE	NAME
DRAWN	11/22/22	BJJ
CHECKED		
ENG APPR.		
MFG APPR.		
Q.A.		

COMMENTS:

**McGuire  
Mechanism**

SIZE <b>B</b>	DWG. NO. HNC-03	REV A
------------------	--------------------	----------

SCALE: 1.5:1	WEIGHT:	SHEET 1 OF 1
--------------	---------	--------------