

REVISIONS				
ZONE	REV.	DESCRIPTION	DATE	SIGNED
	A	NEW RELEASE	11/22/2022	BJJ

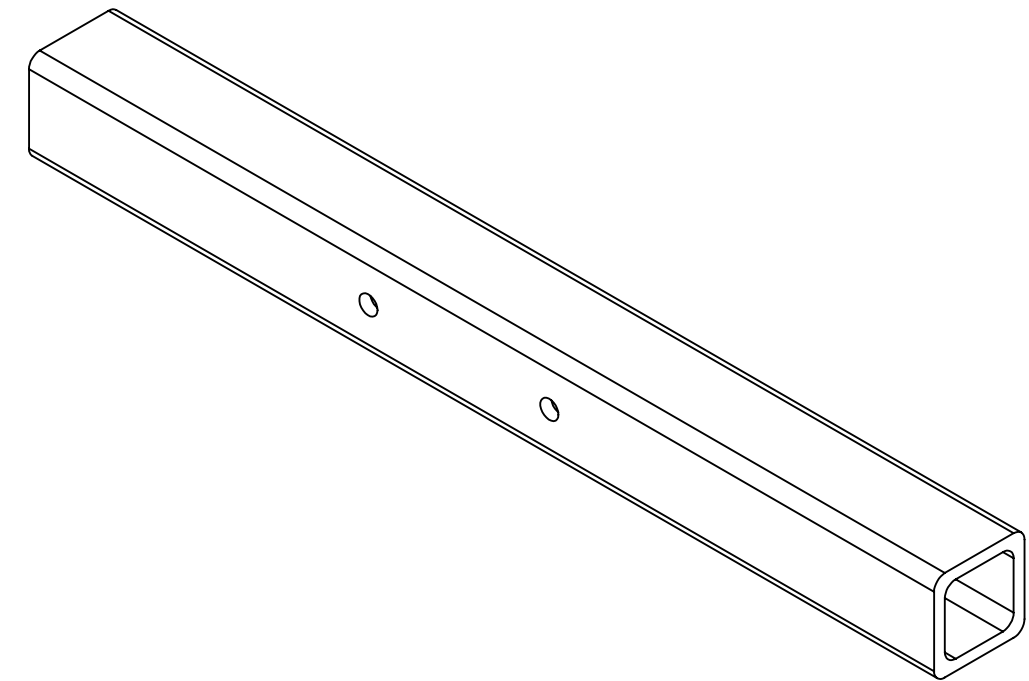
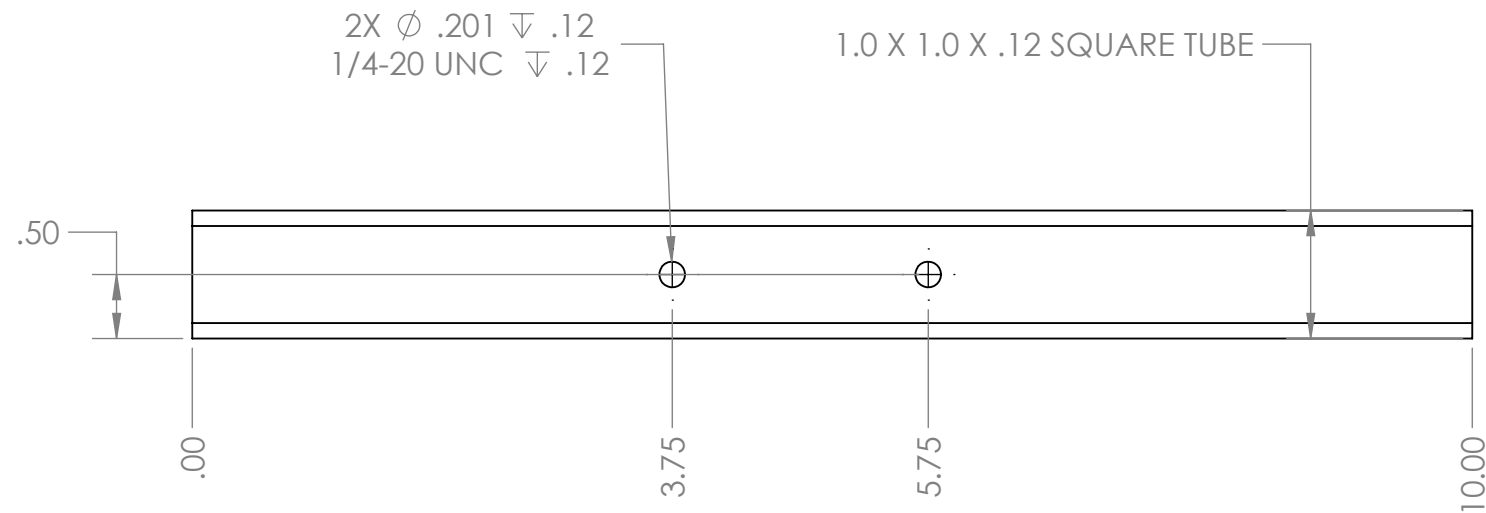

# HNC-01(SHEET 1 OF 1) BOTTOM TUBE

**PROPRIETARY AND CONFIDENTIAL**  
THE INFORMATION CONTAINED IN THIS DRAWING IS THE SOLE PROPERTY OF MCGUIRE MECHANISM. ANY REPRODUCTION IN PART OR AS A WHOLE WITHOUT THE WRITTEN PERMISSION OF MCGUIRE MECHANISM IS PROHIBITED.

UNLESS OTHERWISE SPECIFIED:  
DIMENSIONS ARE IN INCHES  
TOLERANCES:  
FRACTIONAL  $\pm 1/8"$   
ANGULAR: MACH  $\pm 0.1^\circ$   
BEND  $\pm 2^\circ$   
TWO PLACE DECIMAL  $\pm .030$   
THREE PLACE DECIMAL  $\pm .005$   
FOUR PLACE DECIMAL  $\pm .0005$

MATERIAL PLAIN CARBON STEEL

FINISH

	DATE	NAME
DRAWN	11/22/22	BJJ
CHECKED		
ENG APPR.		
MFG APPR.		
Q.A.		

COMMENTS:



SIZE **B** DWG. NO. HNC-01 REV **A**

SCALE: 1:2 WEIGHT: SHEET 1 OF 1